



*Lot 316*  
*66 Shepherds Bush Road*  
*Hunua Views*

*Super quality 2 Bed*  
*Standalone Villa*



HUNUA  
VIEWS



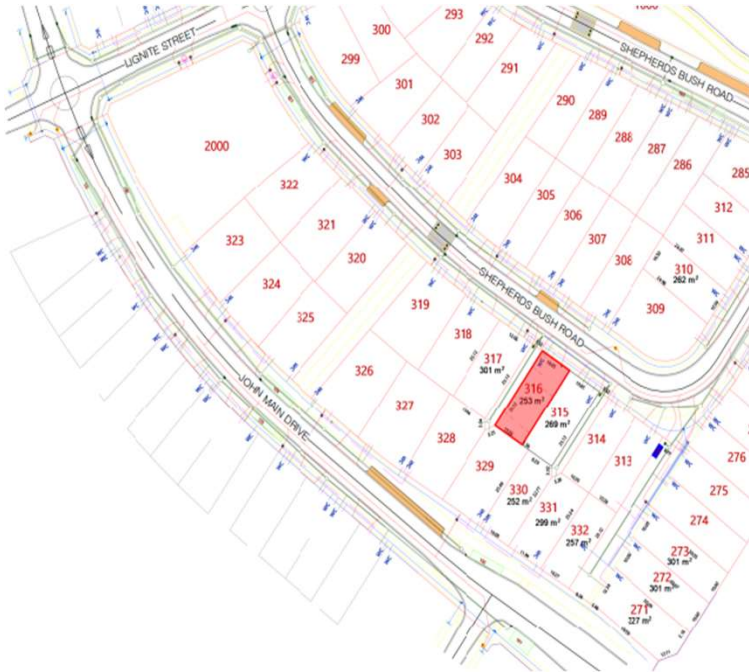

# Index

1. Proudly Kiwi
2. Why build with Generation Homes
3. Standard home features
4. Floor Plan
5. Elevations
6. Base cost component options
  - Kitchen finish - tapware sinks cabinet finishes
  - Appliance packages
  - Bathroom finish - tiles tapware bath basin etc
  - Flooring – tile and carpet
  - Wardrobe plan
7. Outside base quote - Components Generation homes can source, have installed and warranted ready when you move in
  - Appliance packages
  - Wardrobe fit outs
  - Blinds and internal shutters
  - Smart tech
  - Car chargers





# Proudly Kiwi

We're a proud Kiwi company that was established in Tauranga more than 20 years ago. We built our foundation on trust and results. Founders David Mansel and Graham Hockly, who both started in the building trade in Tauranga, now head one of the country's leading residential construction companies.



Both David and Graham remain strong in the belief that building doesn't need to be a stressful, time-consuming and cost spiralling exercise. Their aim has always been to provide certainty in the uncertain world of building, and that means creating and implementing simple, streamlined processes and refining them over the years.

With nine branches throughout New Zealand, our point of difference is delivering fixed price homes with a guaranteed move in date. People who build with Generation Homes enjoy the budget security of a fixed price

contract – including all fees needed to get the build underway, and every cost thereafter – right down to the number on the letterbox. There are no hidden costs.

With extensive experience in residential building and development, Generation Homes has established a reputation for reliability, quality and exceptional customer service. Over 6,000 homes have been built by Generation Homes across New Zealand.

Building a community for every generation is at the heart of our business.





# Why Generation?

## Making building easy for 24 years.

Over the past 21 years we have built nearly 5,500 new homes. 100% were delivered for the price we promised and 97% were delivered on the day we promised.

So when you buy a house and land package from Generation Homes you'll have peace of mind knowing that there will be no unexpected or hidden costs and you can get on with planning your move confident that your house will be ready on time.



### PROVEN DELIVERY

- We are one of New Zealand's largest and most successful residential building companies.
- Established in 1997, we've been building homes for close to 25 years.
- To date we've built over 5,500 homes.

### SPOILT FOR CHOICE

- Choose from a range of 200 architecturally designed plans.
- We offer expert design advice from our sales team, or select from our professional colour consultant design boards!
- Looking at our smaller offer? We have specifically designed custom plans in our smaller subdivisions to maximise forwards and backwards viewing windows. Just because a site is narrow doesn't mean you should be looking at your neighbours and through smart design we make the most of the your space.

### FIXED PRICE GUARANTEE

- The contract price is the price you pay. Once you have chosen your plan and variations, we offer a fixed price that doesn't change.
- Of the 5,500 homes we have built to date, 100% were built for the price we promised.



## Making building easy for 24 years

### QUALITY ASSURED

- To date we've won 8 Master Builder quality awards.
- Our national supplier and contractor agreements guarantee quality delivery, ensuring the quality of our builds are consistent from one home to the next.
- All our homes are backed by a 10 year Master Builder Guarantee and a 12 month warranty on all building works.
- Generation Homes has a strong commitment to work closely with our suppliers/ contractors and always pay them on time.
- This means we work with the best in the industry to provide you with the assurance that your build is in good hands.

### LOCAL EXPERTISE, NATIONAL CLOUT

- We're not a franchise, we're 100% owned by Generation Group Limited.
- So, if something were to go wrong, you'll have the backing of an established national organisation. We have never failed to complete a house.

### WE'RE GOOD COMMUNICATORS

- We listen and help you choose the right home for you and your family.
- We are passionate about building and take pride in what we can do in conjunction with you.

### WE HAVE BEEN IN YOUR SHOES

- Our team in the Auckland South area have experience buying, building or even starting out on the property ladder in the recent market climate.
- Some of our team even joined after building with Generation Homes. We understand what its like to be on the client end.
- For first home buyers, we understand the Home Start Grant and Kiwi saver withdrawal process and can work with you to help ensure all the timelines match up to help make the process as smooth as possible.
- We have some great industry contacts & can help point you in the right direction.

# STANDARD FEATURES

## INCLUDED IN YOUR HOME

	ITEM	DESCRIPTION	*MAKE	MODEL
Preliminary and General	Builders Guarantee	Residential 10 Year Standard Cover		
	Full Working Drawings	Ready to lodge with Council		
	Engineering Design	Site Specific Foundation Design		
	Building Consent	Issued by Territorial Authority		
	Inspections and CCC	Issued by Territorial Authority		
	Insurance	Construction and public liability		
	Defects service period	12 months		
Site Works and Floor	Site Preparation	Up to 300mm topsoil site scrape to building platform only. Finished with GAP7 aggregate		
	Foundations	Site specific engineered designed Raft Concrete Floor		
	Sewer and Stormwater	Connected to existing onsite connections		
Construction	Framing Interior	H1.2 treated timber		
	Framing Exterior	H1.2 treated timber, H3.2 bottom plate		
	Roof Covering	Long-run	Colorsteel	
	On Site Safety	Scaffold, Edge Protection and safety nets		
	Fascia/Spouting	Colorcote	Continuous	125 OG internal Brackets
	Downpipes	Colorcote	Continuous	80mm DIA.
	Ceiling height	2.40m high flat Ceiling downstairs, 2,40m high flat upstairs		Classic Flat Face
	External Joinery & Windows	Powder Coated Aluminium window and door system with propriety hardware. Double glazed units (sub new build regulations)	Fairview	Mistlite
	Obscure Glass	WC, bathroom, ensuite and front entry door sidelight (if applicable).	Fairview	PTF
	Window Reveals	Pre-primed 18mm pine		
	Entry Door	Powder coated T&G with Boston Gripset hardware	Fabtech	
	Insulation	Exterior walls, Ceiling , Pink Batts		
	Soffits	Painted	James Hardie	

\*Features are subject to change, providing the goods used are of equal or better quality as those listed here.

# STANDARD FEATURES

## INCLUDED IN YOUR HOME

	ITEM	DESCRIPTION	*MAKE	MODEL	
Interior	Walls	10mm Plaster board stopped to level 4 paint finish	GIB Board		
	Ceilings	13mm Plaster board stopped to level 4 paint finish	GIB Board		
	Bathrooms	Aqua Line (Water resistant)	GIB Board		
	Interior Doors	TBA			
	Interior Door Hardware	Interior door lever handles Entrance lock to garage Passage hardware to bedrooms Privacy locks to bathrooms Flush pull handles to sliding wardrobes (if applicable) Dummy hardware with magnetic catches to cupboards			
	Architraves	Windows and doors Claymark M76 90mm paint finish		Finger joined pine	
	Skirtings	Claymark M77 130mm Paint Finished – to carpeted areas only (tiles – none)		Finger joined pine	
	Scotia	None, square stopped			
	Slimlines	Square stop external corners			
	Paint	All finished 3 coats (1 colour to walls and lighter shade to ceilings) level 4 to all surfaces	Resene		
	Cupboard fit outs	Ventilated wire system as per plan	Designer Homeware		
	Cleaning	Professional builders clean on completion & rubbish removed			
	Kitchen	Custom Built Kitchen	Design as per kitchen plan – Final plan to be advised		
		Cabinets	Melteca		
Doors		As per kitchen plan			
Bench Tops		Laminex 37mm option 20mm Caesarstone			
Sink		As per kitchen plan			
Sink Mixer		Studio Pin Sink Mixer	Englefield		

# STANDARD FEATURES

## INCLUDED IN YOUR HOME

	ITEM	DESCRIPTION	*MAKE	MODEL
Appliances	Oven	Wall Oven 7 function 60cm	Bosch	HBF113BR0A
	Hob	Electric Touch Cooktop 60cm	Bosch	PKE611K17A
	Rangehood	Ariston Power Pack 60cm	Ariston	ARU52AX-L
	Dishwasher	F/S 6prg Dishwasher 60cm	Bosch	SMS4HTI01A
	Fridge	Pre-plumbed Water to Fridge		
	Heatpump	Dual Zone to Meet Accessibility Living Standards		
Plumbing	All polyethelene pipe work	Hot & Cold Water		
	2x Outdoor Taps			
	Hot Water Cylinders	Mains pressure 180L	Rheem	
	Laundry	Laundry Tubbie	Raymor	
	Laundry Mixer	Studio Pin Basin Mixer	Englefield	97531-A-4
Bathroom/ Ensuite	Shower	Tiled showers as per plans, Toughened Glass Door		
	Inline Extraction Fan	361m3/h with timer	Fantech	LK150NTP
	Shower Mixer	Studio Pin Level	Englefield	975334-4
	Shower Head	Studio Pin Slider Shower	Englefield	29689A
	Basin Mixer	Studio Pin	Englefield	97531A-4
	Bath	Sorrento 11 - 1675 Bath	Englefield	
	Bath Mixer & Spout	Studio Pin Lever Wall Mount	Englefield	20149A-4
	Vanity	Raymor Boston Wall hung Vanity – 1 drawer		
	Mirror	Frameless – TBC		
	Heated Towel Rail	Heated Towel Rail 7 Bar	Genesis	WG825
	Toilet	Mila Back to Wall Toilet Suite 3.5L Flush	Adesso	

\*Features are subject to change, providing the goods used are of equal or better quality as those listed here.



# STANDARD FEATURES

## INCLUDED IN YOUR HOME

	ITEM	DESCRIPTION	*MAKE	MODEL
Electrical	Temporary Power	Builders temporary supply during construction		
	Light Outlets	In ceiling recessed LED downlights as per electrical plan		
	Two Way Light Circuits	As per electrical plan		
	Power Points	As per electrical plan	PDL	S600
	Television Outlets	As per electrical plan		
	Television Aerial	UHF		
	Telephone Outlets	As per electrical plan		
	Security	Wiring only for alarm		
	Smoke Alarms	Included		
Pre-wire for electric vehicle charger	Included			
Tiling and Flooring	Wall Tiles	Splashbacks as per plan to kitchen and vanities		
	Floor Tiles	As per Enzo collection		
	Floor Tiles	Entry, Kitchen, bathroom, ensuite and laundry		
	Carpet	100% premium 26oz soft solution dyed nylon to non-tiled areas	Belgotex	Liberty
	Underlay	9mm		
Landscaping	Driveway, Terraces & Paths Fencing	As per Hunua Design Guidelines		
	Garden Shed	Semi-permeable paving to address off street parking.		
	Clothesline	Location to be set in Landscaping Plan		
	Planting & Lawn			
	Letterbox			

\*Features are subject to change, providing the goods used are of equal or better quality as those listed here.

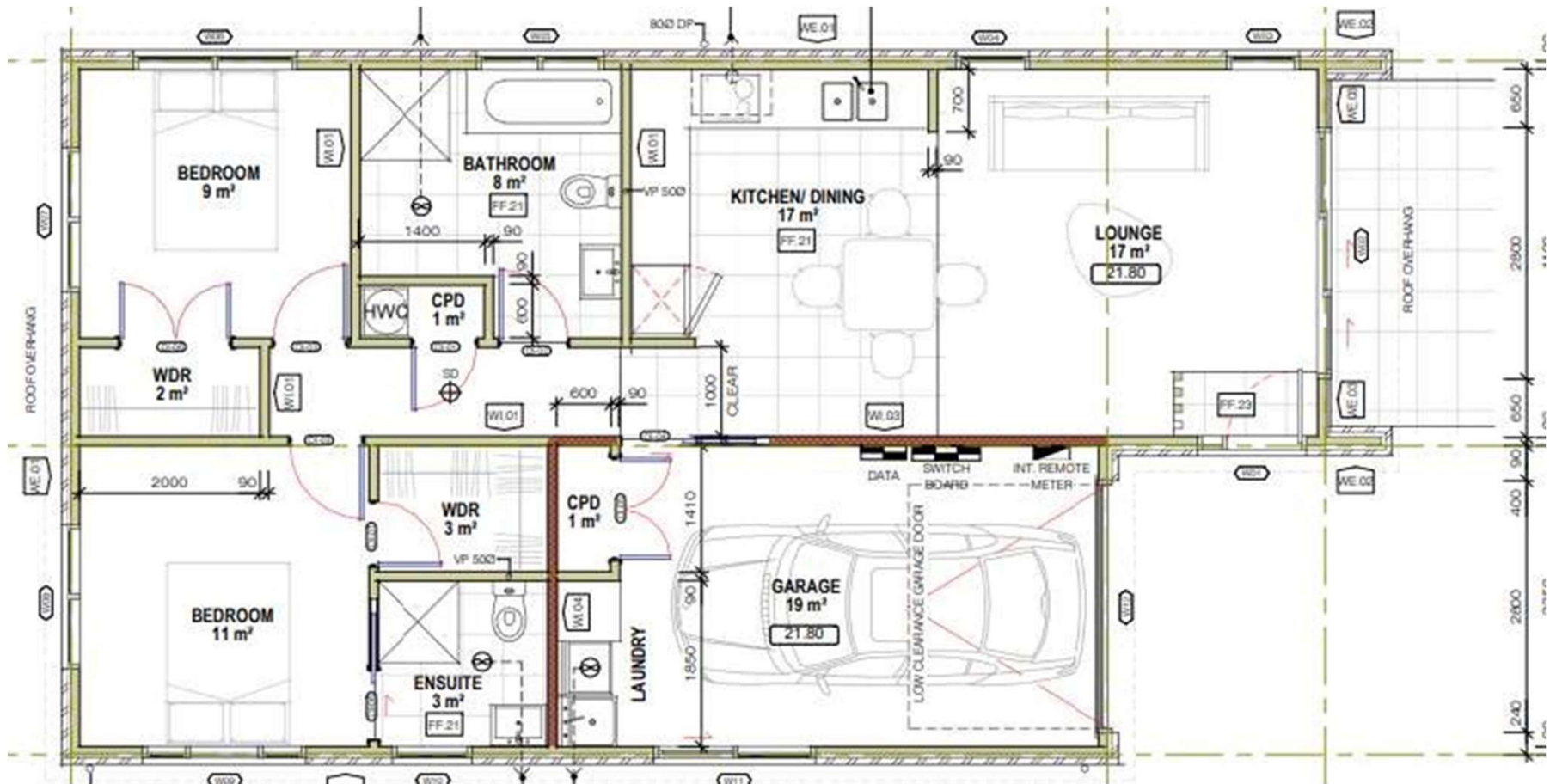

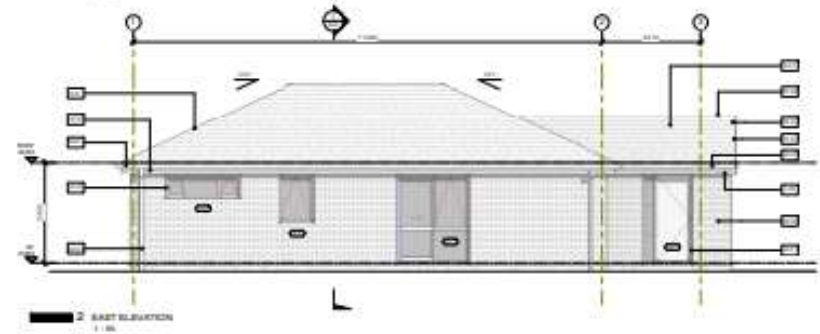
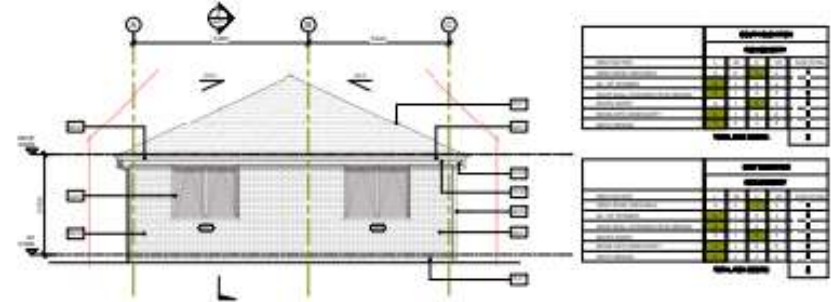
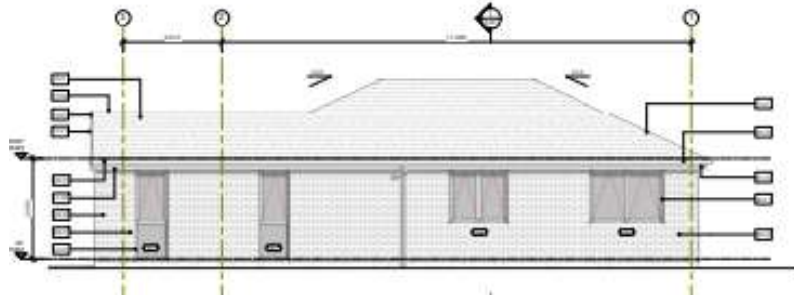
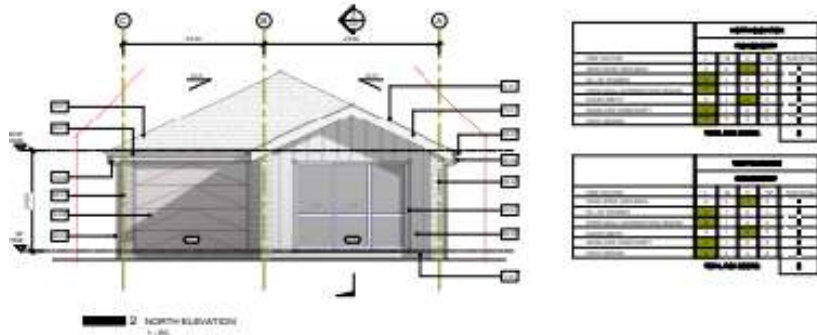

# Bedrooms Ventilated



Designer Homeware (NZ) Ltd  
 0508 2 ORGANISE (67426)  
[www.designerhomeware.co.nz](http://www.designerhomeware.co.nz)

EXAMPLE

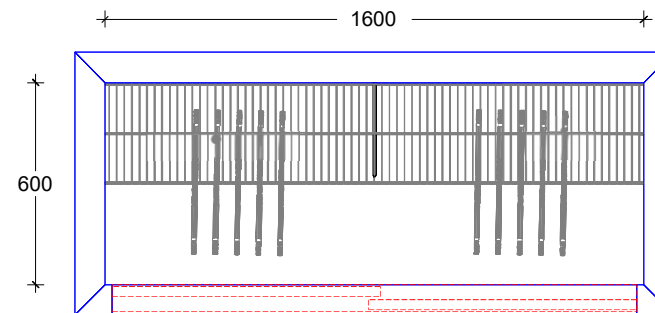
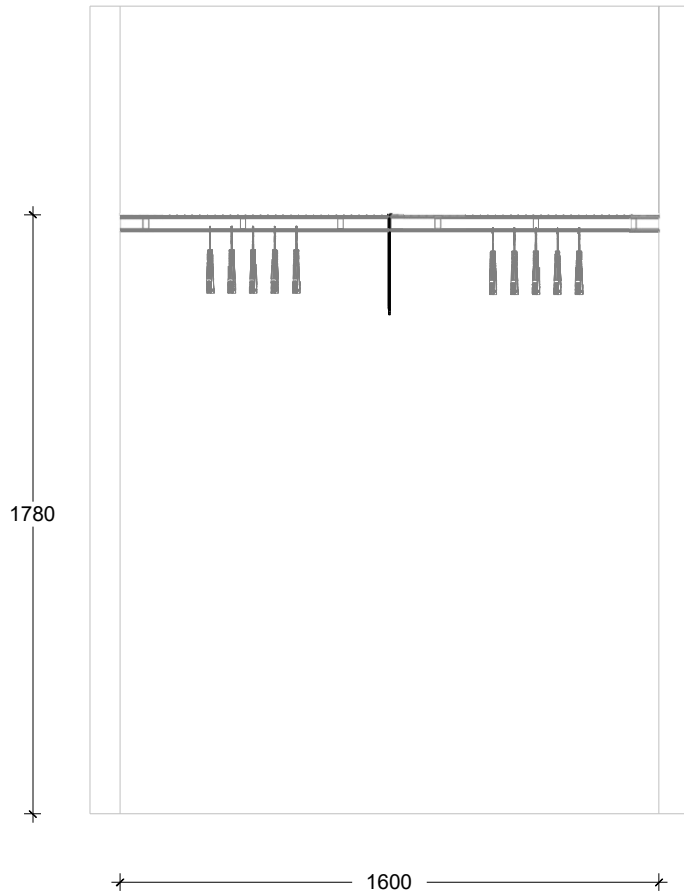

Double Sliders

Type: 300 S&R

All dimensions & size designations are subject to site verification and adjustment to fit job conditions. This is an original design and must not be released or copied unless an application fee has been paid or a job order placed.

Designer: Ivy Lee  
 Print Date:            of 6

Plans and Specifications Approved:  
 .....  
 Date: .....

# Hotwater Cupboard Ventilated

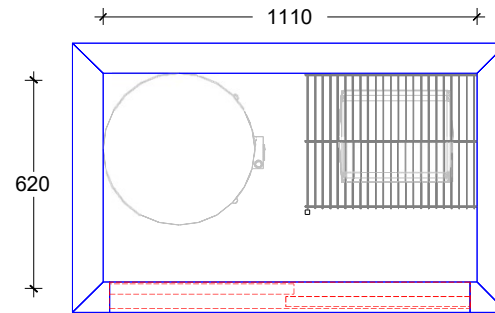
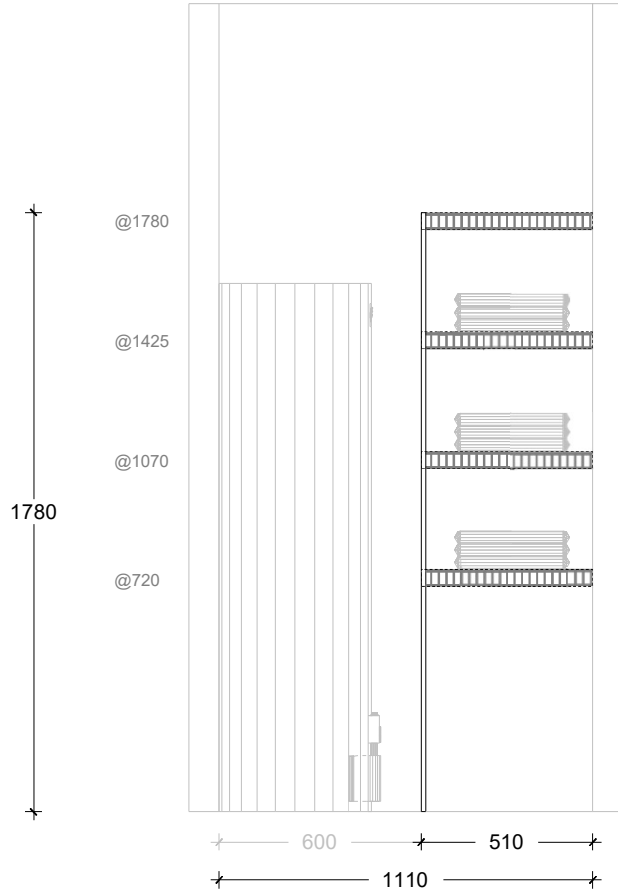

Double Sliders



Designer Homeware (NZ)  
 Ltd 0508 2 ORGANISE  
 (67426)  
[www.designerhomeware.co.nz](http://www.designerhomeware.co.nz)

**EXAMPLE**

**Type: 400 Linen**

All dimensions & size designations are subject to site verification and adjustment to fit job conditions. This is an original design and must not be released or copied unless an application fee has been paid or a job order placed.

Designer: Ivy Lee  
 Print Date: \_\_\_\_\_ of 6

Plans and Specifications Approved:

.....

Date: .....

# APPLIANCES



Your Generation appliance package comes with a 5 Year Warranty

5 Year warranty covers the Oven, Cooktop, and dishwasher - Refrigeration are covered for 2 years.

Colour Disclaimer: Please note colours may vary, it is recommended to go view the colours prior to making a decision.



# APPLIANCES

## Stainless Steel Appliance Pack



**Bosch F/S Dishwasher 60cm 6prg**

Model : SMS4HTI01A



**Ariston 80cm Power Pack Rangehood**

Model : ARU75AX-L



**Bosch 60cm Built-in Oven 7 FUNCTION**

Model : HBF113BR0A

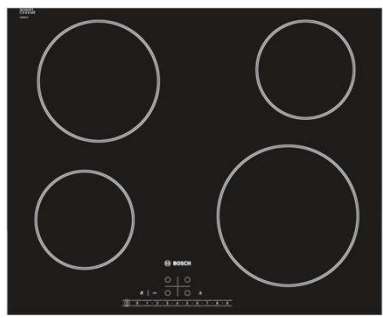

**Bosch 60cm Touch Ceran Cooktop**

Model : PKE611K17A



# BATHROOMWARE



Colour Disclaimer: Please note colours may vary, it is recommended to go view the colours prior to making a decision.

**mico** design







**Chrome**

Tap Height: 141mm

Spout Reach: 101mm

Suitable for mains pressure.

5 Star WELS, 6L/min

Warranty



**Chrome**

80mm Diameter Face Plate

Suitable for mains pressure.

Warranty



**Chrome**

Suitable for mains pressure.

3 Star WELS, 9L/min

Warranty

# TILES



Colour Disclaimer: Please note colours may vary, it is recommended to go view the colours prior to making a decision.

Price Disclaimer: Please note certain designs and personal consultations fall outside of the contractual price, these will be raised as soon as possible.

the **tile depot**



# TILES

## Base Enzo Collection



ENZO MOON



ENZO CINDER



ENZO SAND



ENZO COAL



# CARPET

## Luxurious Carpets of great design & texture

A range of durable carpets that retain their look & style much longer than other carpet fibre types.

A wide range of carpets that are resistant or proof to spills, staining, fading, with anti-static and anti-soiling properties. These carpets are easy to clean & maintain and great for any floor areas in your house – bedrooms, living rooms, offices & more.

Colour Disclaimer: Please note colours may vary, it is recommended to go view the colours prior to making a decision.

# Belgotex®

INTERNATIONAL CARPET & FLOORING



Construction	Tufted Cut Pile Carpet
Yarn	100% Solution Dyed Nylon
Width	3.66m
Standard Roll Length	35m
Yarn Weight	900g/m <sup>2</sup> / 26.5oz/yd <sup>2</sup>
Total Weight	1850g/m <sup>2</sup>
Pile Height	7.5mm
Total Thickness	9.5mm
Machine Gauge	1/8th
Primary Backing	Woven Polypropylene
Secondary Backing	Action Fleece
Electrical Properties	Antistatic
Electrical Propensity	< 2kV
Fire Rating	ISO 9239-1
Anti-allergenic Properties	Will not shed or pill. Resistant to mould & mildew.
Underfloor Heating	Suitable
Rating	Extra Heavy Duty Residential / Light Commercial
Stair Rating	Suitable
Warranties	<b>10 Year Living Warranty</b> 10 Year Residential Wear Warranty 10 Year Stain Resistant Warranty 10 Year Fade Resistant Warranty 10 Year Colourfast Warranty 5 Year Manufacturing Defects Warranty 5 Year Commercial Wear Warranty
Environmental	Low VOC, solution dyeing uses no water ISO 14001, CRI Green Label Plus Certified

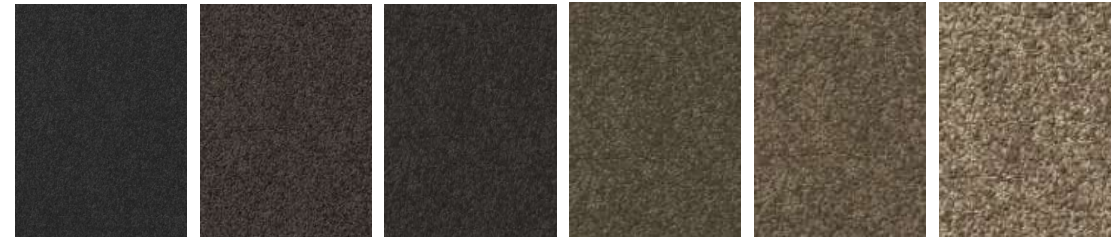

Ash      Bark      Charcoal      Cinder      Clay      Copper



Fossil      Gravel      Iron      Nickel      Oxide      Pearl



Spice      Titanium      Zinc

# PAINT



Colour Disclaimer: Please note colours may vary, it is recommended to go view the colours prior to making a decision.

**Resene**  
the paint the professionals use

# PAINT

## Resene



QUARTER SEA FOG

[INTERIOR](#)



*Resene Half Barely There*

HALF BARELY THERE



*Resene Quarter Fossil*

QUARTER FOSSIL



*Resene Quarter Fuscous Grey*

QUARTER FUSCOUS GREY

[INTERIOR](#)



*Resene Half Sea Fog*

HALF SEA FOG



*Resene Black White*

BLACK WHITE

# Colours Exterior choices



## ROOF

GREY FRIARS

[LONGRUN METAL](#)

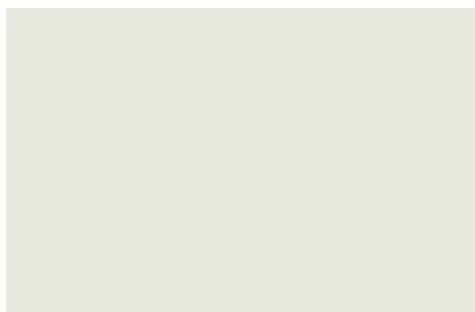

## WINDOW JOINERY

LIGHT JOINERY TO MATCH

[DG ALUMINIUM](#)



## BRICK CLADDING

CREVOLE with white mortar

[MASONRY VENEER](#)

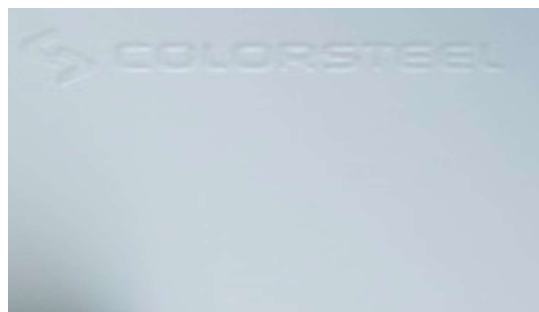

## ROOF

TITANIA

[LONGRUN METAL](#)



## FRONT DOOR

OPTIONAL COLOURS AVAILABLE

[ALUMINIUM](#)



## BRICK CLADDING

RUST with grey mortar

[MASONRY VENEER](#)



# Colours Exterior



## CLADDING

RESENE MILK WHITE

[TIMBER BATTENS, OVER  
RUSTICATED  
WEATHERBOARDS](#)



## SOFFITS

RESENE HALF HEATHERED GREY

[TIMBER](#)



## SPOUTING & FASCIA

TITANIA

[COLORSTEEL](#)



## CLADDING

RESENE MILK WHITE

[BEVELBACK  
WEATHERBOARDS](#)



## DOWNPIPES

WHITE

[PVC](#)



## EXTERIOR FENCES

RESENE GREY

[TIMBER](#)